

Ultrasonic thermal energy meter for in-line installation



- Detection of backflow and air
- High temperature resistant for district heating (special version)
- Dynamic temperature measuring cycle: 2/60 s
- Measuring cycle of flow rate: 2 s
- Inlet or outlet and unit of measurement can be set on site
- Detachable calculator, 85 cm cable (2.85 m upon request)
- Communication interfaces:
 - wireless M-Bus
 - wireless M-Bus + 3 pulse inputs
 - M-Bus
 - M-Bus + 3 pulse inputs
 - 2 pulse outputs
- Replaceable battery, service life 10 years
- Ready for external power supply

TECHNICAL DATA

Water meter

Measuring method		Ultrasonic, time-of-flight							
Nominal flow rate q_p	m ³ /h	0.6	1.5	1.5	2.5	3.5	3.5	6.0	10.0
Low flow rate threshold	l/h	6	6	6	12	14	14	30	30
Minimum flow rate q_i	l/h	12	12	12	25	28	28	60	100
Maximum flow rate q_s	m ³ /h	1.2	3.0	3.0	5.0	7.0	7.0	12.0	20
Pressure drop Δp at q_p	bar	0.03	0.21	0.04	0.12	0.21	0.21	0.20	0.11
Pressure drop Δp at q_s	bar	0.13	0.85	0.17	0.46	0.89	0.89	0.80	0.43
Nominal diameter	mm	DN15	DN15	DN20	DN20	DN20	DN25	DN25	DN 40
Thread	inch	G3/4B	G3/4B	G1B	G1B	G1B	G1 1/4B	G1 1/4B	G2B
Length	mm	110	110	130	130	130	150	150/260	200/300
Dynamic range q_i/q_p	-	1:50	1:125	1:125	1:100	1:125	1:125	1:100	1:100
Accuracy class (MID)		class 2							
Nominal pressure PN	bar	16							
Temperature range of medium – heat	°C	15-90 (standard) 15-130 high temperature (150 for max. 2000 hours), (optional)							
Temperature range of medium – cooling (q_p 1.5 to q_p 6)	°C	5-50							
Temperature range of medium – heat/cooling	°C	15-90 heat (standard) 15-120 high temperature (optional) 5-50 cooling							
Installation point		Inlet or outlet Can be set if the energy value is \leq 10 kWh							
Mounting position		Any							
Protection class		IP65							

Calculator

Temperature range of medium	°C	0-150 heat 0-50 cooling (q_p 1.5 to q_p 6)
Operating ambient temperature	°C	5-55 with 95% relative humidity
Transport temperature	°C	-25-70 (max. 168 hours)
Storage temperature	°C	-25-55
Temperature difference range $\Delta\theta$ heat	K	3-100
Temperature difference range $\Delta\theta$ cooling	K	-3- -50
Minimum temperature difference $\Delta\theta$ heat	K	> 0.05
Minimum temperature difference $\Delta\theta$ cooling	K	< -0.05
Minimum temperature difference $\Delta\theta_{HC}$ heat/cooling	K	> 0.5/< -0.5
Temperature resolution	°C	0.01
Dynamic temperature measuring cycle	s	2/60; with power pack: 2 s permanently
Flow rate measuring cycle	s	class 2
Display		LCD - 8 digits + special characters
Decimals		Up to 3
Unit of measurement		MWh, kW, m ³ , m ³ /h (kWh, GJ, l, l/h, MW, MMBTU, Gcal); The energy unit can be set if the energy value is \leq 10 kWh.
Interfaces		Optical interface (M-Bus protocol) Optional: wireless M-Bus, wireless M-Bus + 3 pulse inputs, M-Bus, M-Bus + 3 pulse inputs, 2 pulse inputs
Power supply		Replaceable 3 V lithium battery; all models are prepared for a 3 V power pack (input voltage 230 V/24 V)

Estimated lifetime	Years	10; see "Factors influencing battery lifetime" (Maddalena technical documents)
Data storage		Non-volatile
Reading dates		Selectable yearly reading date 15 monthly and semi-monthly values via display or wireless M-Bus (compact mode); 24 monthly and semi-monthly values via optical interface or M-Bus.
2 tariff registers		Can be set individually; energy or time can be added
Storage of maximum values		Power, power and temperature (inlet, outlet, $\Delta\theta$) and related values of the latest 15 months included
Protection class		IP65
CE		Yes
Electromagnetic interference		EN 1434
Detachable calculator housing (h x w x p)	mm	75 x 110 x 34.5

Temperature sensors (2-wire technique)

Platinum precision resistor		Pt 1000
Diameter	mm	5; 5,2; 6; AGFW 27,5; 38; needle sensor 3.5 x 75
Cable length	m	1,5; 3; 6
Installation point		Asymmetrical, symmetrical

Dimensions

q_p (m ³ /h)	Nominal diameter	G (")	L (mm)	H (mm)	A (mm)	Weight (basic version)
0.6	DN15	G3/4B	110	65	37	0.720
1.5	DN15	G3/4B	110	65	37	0.720
1.5	DN20	G1B	130	65	37	0.770
2.5	DN20	G1B	130	65	37	0.770
3.5	DN20	G1B	130	65	37	0.770
3.5	DN25	G1 1/4B	150	65	37	0.930
6.0	DN25	G1 1/4B	150	67.5	39.5	0.930
6.0	DN25	G1 1/4B	260	67.5	39.5	1.200
10.0	DN 40	G2B	200	73	45	1.580
10.0	DN 40	G2B	300	73	45	2.050

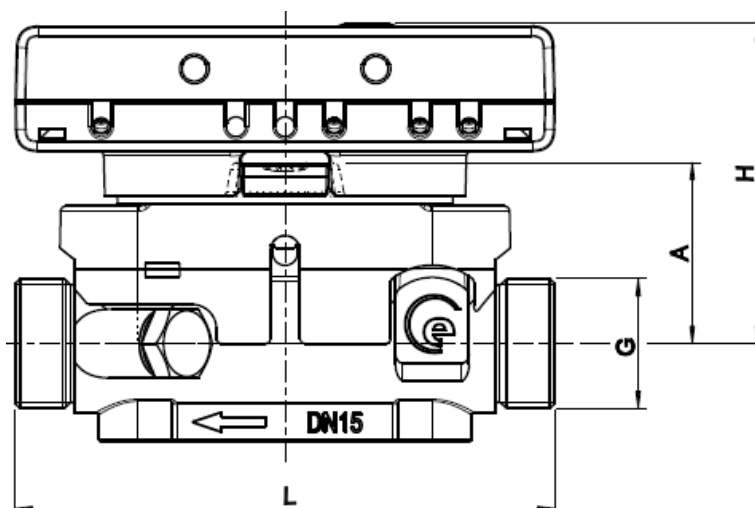

HEAD LOSS

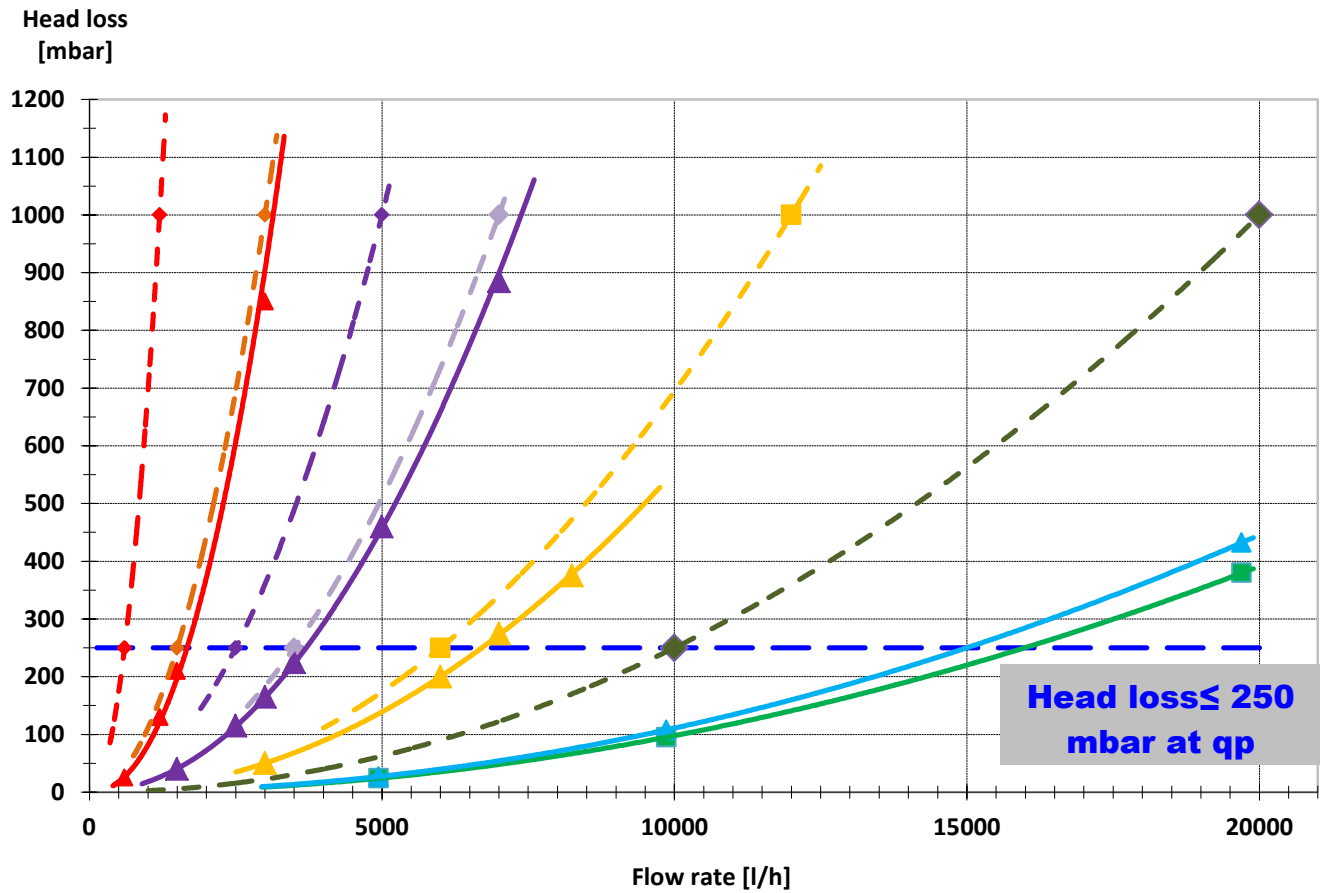

- ◆ EN1434 Limit qp0,6
- ◆ EN1434 Limit qp1,5
- ◆ EN1434 Limit qp2,5
- ◆ EN1434 Limit qp3,5
- ◆ EN1434 Limit qp6,0
- ◆ EN 1434 Limit qp10
- ▲ pressure drop qp 0,6 / 1,5
- ▲ pressure drop qp 2,5 / 3,5 / 1,5 (DN20)
- ▲ pressure drop qp 6,0
- pressure drop qp 10 200 mm
- ▲ pressure drop qp 10 300 mm
- EN 1434